

Content - Questions to be answered

Waste- (water) Treatment

- What is it? From Where & How Much? (quantity & quality)
- Why must wastewater be treated? (Environmental Protection & Legal Framework)
- **How to collect wastewater? (drainage system & other concepts)**
- How does a treatment plant work? (conventional, large treatment plants)
- What to do with the sludge? (sludge treatment & disposal)
- Any other possibilities of wastewater treatment?
- Are these sanitation concepts available & appropriate for all over the world? (alternative concepts)
- How to monitor and evaluate the quality of surface waters? (saprobic system)

Drainage System

two different drainage systems used at urban areas:

(i) Combined Systems:

- Sanitary sewage and rainwater are jointly collected and drained off;

(ii) Separate Systems:

- Separate collection and drainage system for sanitary sewage and rainwater.

Partially separate system:

- Sanitary sewage and polluted street runoff are jointly drained off;
- the widely unpolluted roof runoff is infiltrated on-site.

Austrian guideline:

- Communities with less than 500 residents have to build separation systems.

Design of Sewer Systems

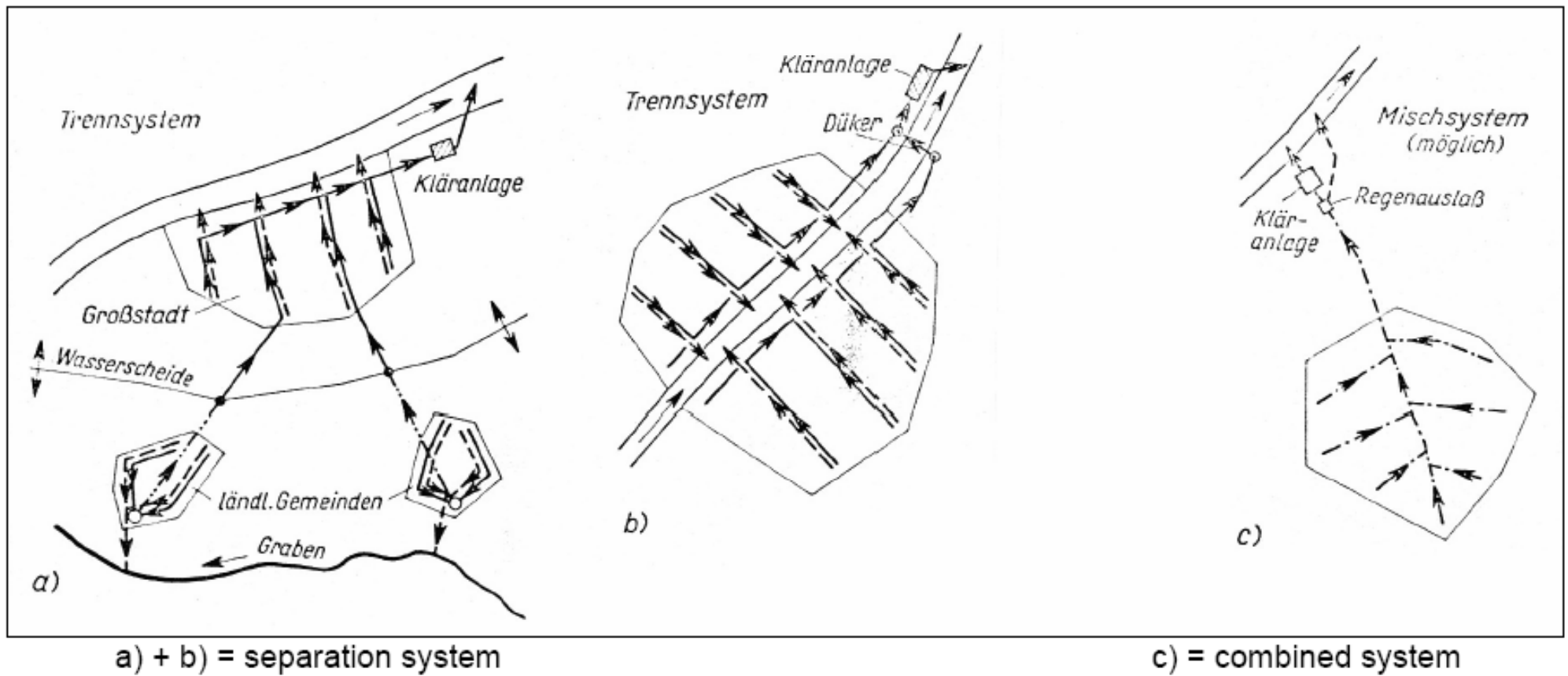

Combined Sewer

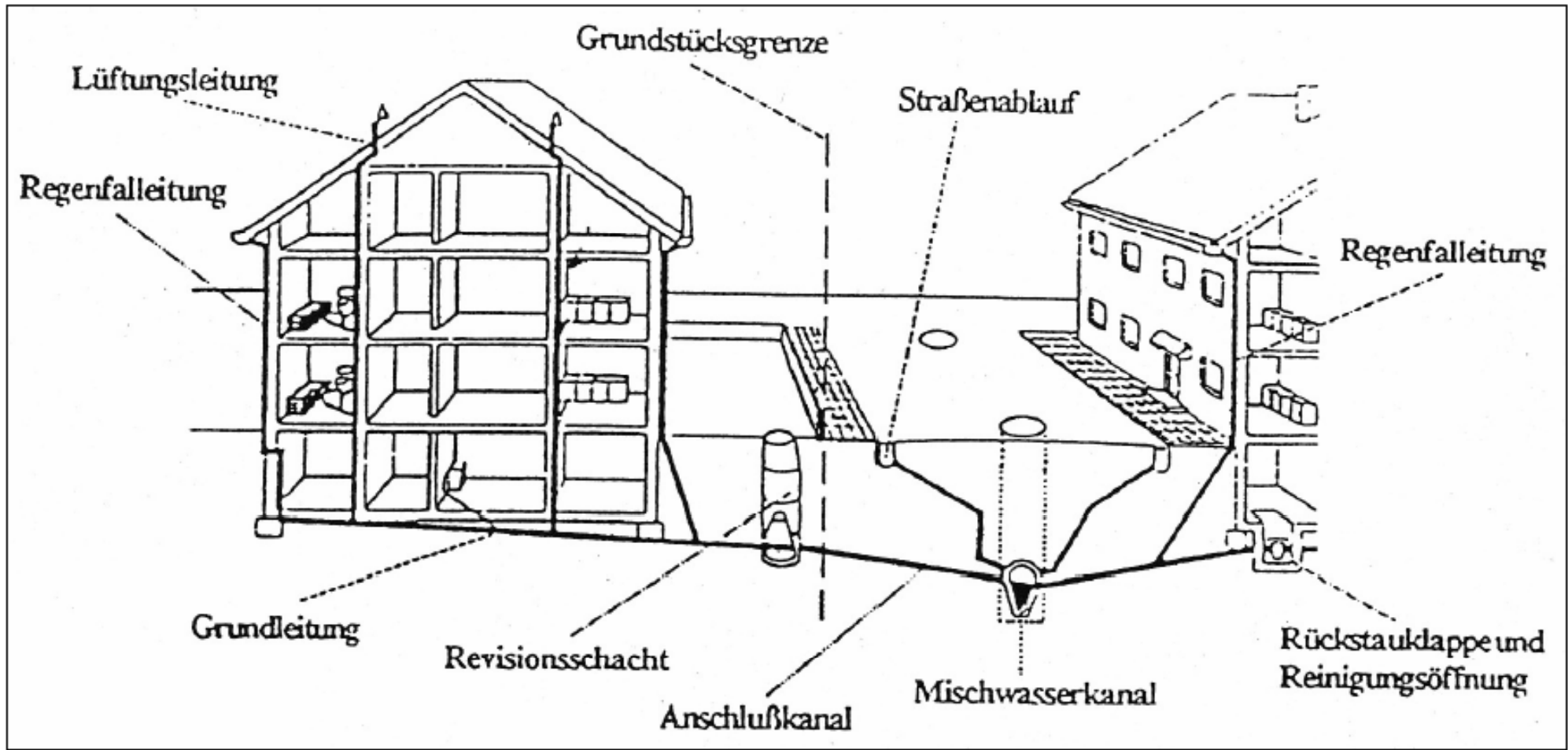

Combined sewer

Separation Sewer

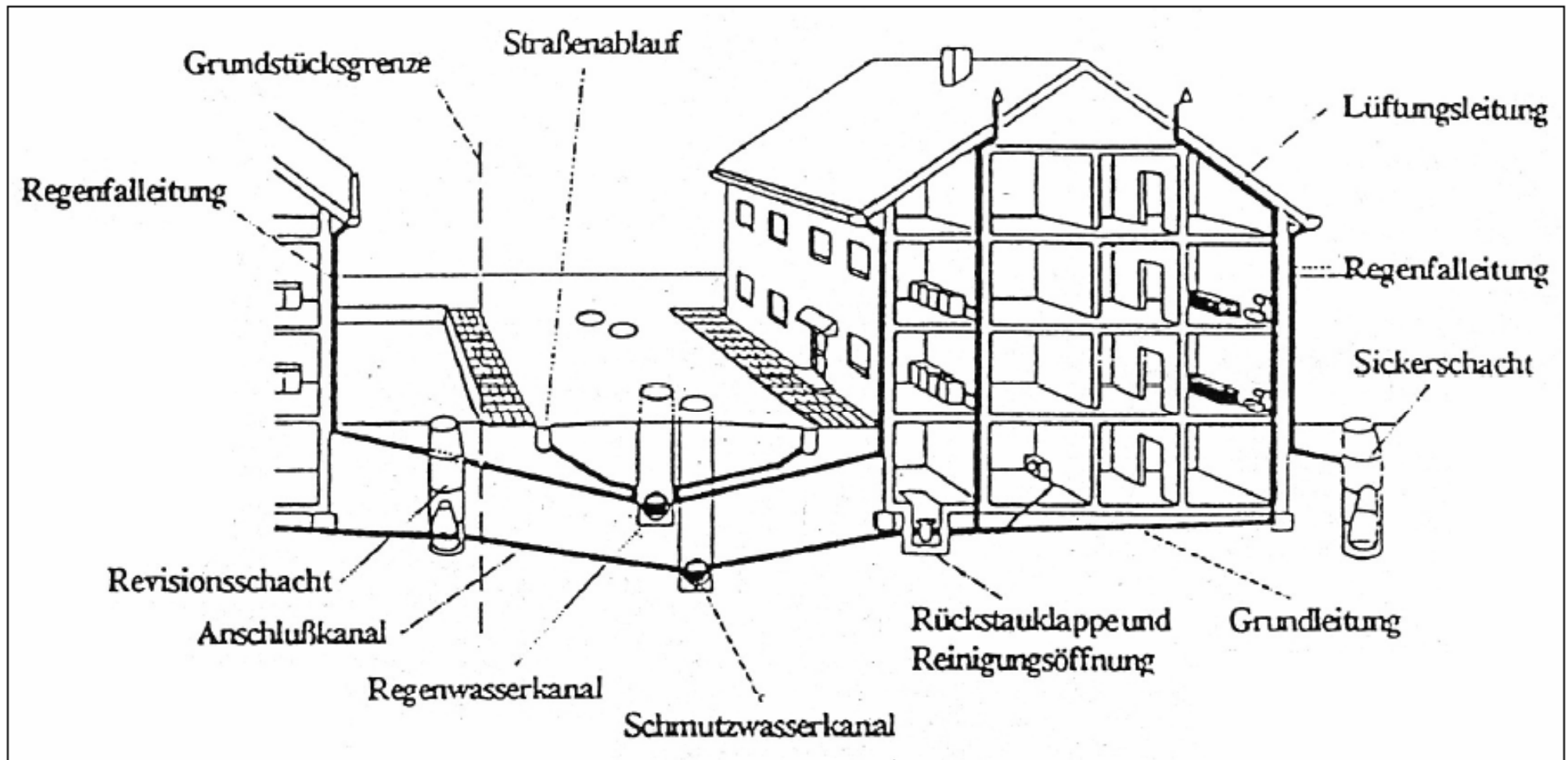

Separation System

Separate system

Rainwater runoff is widely unpolluted and can be discharged without treatment.

Storm sewer

- Large profile because of high peak flows
- Design by choosing a suitable design storm (annuality / return period)
- Contributing area must be quantified (runoff factor)
- Time of concentration (flow time = overland flow time (roughness, slope, length) + sewer flow time)
- Possible **discharge directly** to a **receiving water** (sufficient capacity)

Foul sewer / sanitary sewer (domestic and industrial wastewater sewer)

- small profile because of relatively constant flow
- Gravity discharge from basement levels result in great depth of the sewer
- Discharge to a receiving river not possible (treatment required)

Separate system

Advantage:

- Stormwater peak flow does not affect the treatment plant
- Save costs at the WWTP

Disadvantage:

- Possible **errors with the connection of service pipes**
(Storm sewer < > Foul sewer)
- Investment costs for two separate systems

Combined system

...has to meet requirements of storm and foul sewer

- Large profile because of high peak flows
- **Special pipe profile** for a safe discharge (flow velocity) of dry-weather flow
- Laid in great depth because of basement level - gravity discharge
- Stormwater overflow necessary (only a partial flow of the stormwater is treated)

Combined system

Advantage:

- Only one sewer system has to be built
- A good share of the stormwater is treated (pollution load / first flush effect)

Disadvantage:

- sedimentation (low flow velocity in case of dry-weather flow)
- Cleaning of large sewer profile is time-consuming and thus costly
- Still high investment costs because of special structures (e.g. stormwater overflow) and larger design of treatment plant)
- Combined wastewater affects the treatment plant

Additional impact (load of pollutants) compared to the separation system:

- **First flush:** Sedimentations formed in sewage network during dry-weather-flow are rinsed at the begin of rainfalls and causes a load impact.
- Overflow stormwater (mixed with wastewater) is discharged into the receiving water

Special solutions - for sparsely populated areas

- Pumping sewer
- Vacuum sewer

Application	Pumping	Vacuum
Low population density	++	++
Low or gradient (flat country)	++	+
High GW level	++	++
Complex underground with hindrances	++	+
Run through protected areas	o	++
Intermittent flow (houses for weekend use or vacation only)	-	++

++ very good; + good; - not appropriate; o neutral



Special solutions - for sparsely populated areas

Advantages of Pumping and Vacuum sewers:

- plastic pipes, small profile run shallow and parallel to the surface (only frost safe)
- Pressure lines and with some restrictions even suction lines can **run uphill**.
- Laying requires only a small open-trench or can be done trenchless
- Little consequence of land subsidence
- Short construction period
- Low maintenance work

Savings of investment costs compared to gravity systems can reach up to 50 %
(not suitable / valid for dense populated areas)

Stormwater management

Decrease of stormwater runoff by disconnecting contributing areas and unsealing surfaces.

- Never discharge runoffs to the sewer, which already have qualities equal to or better than WWTP effluent.
- On site infiltration of stormwater (if possible)
- Stormwater discharge through ditches
- Stormwater retention (using natural basins)

Infiltration through the upper, bioactive soil layer → cleaning the stormwater by filtration and bio-degradation processes.

Stormwater reduction: Retention & Infiltration

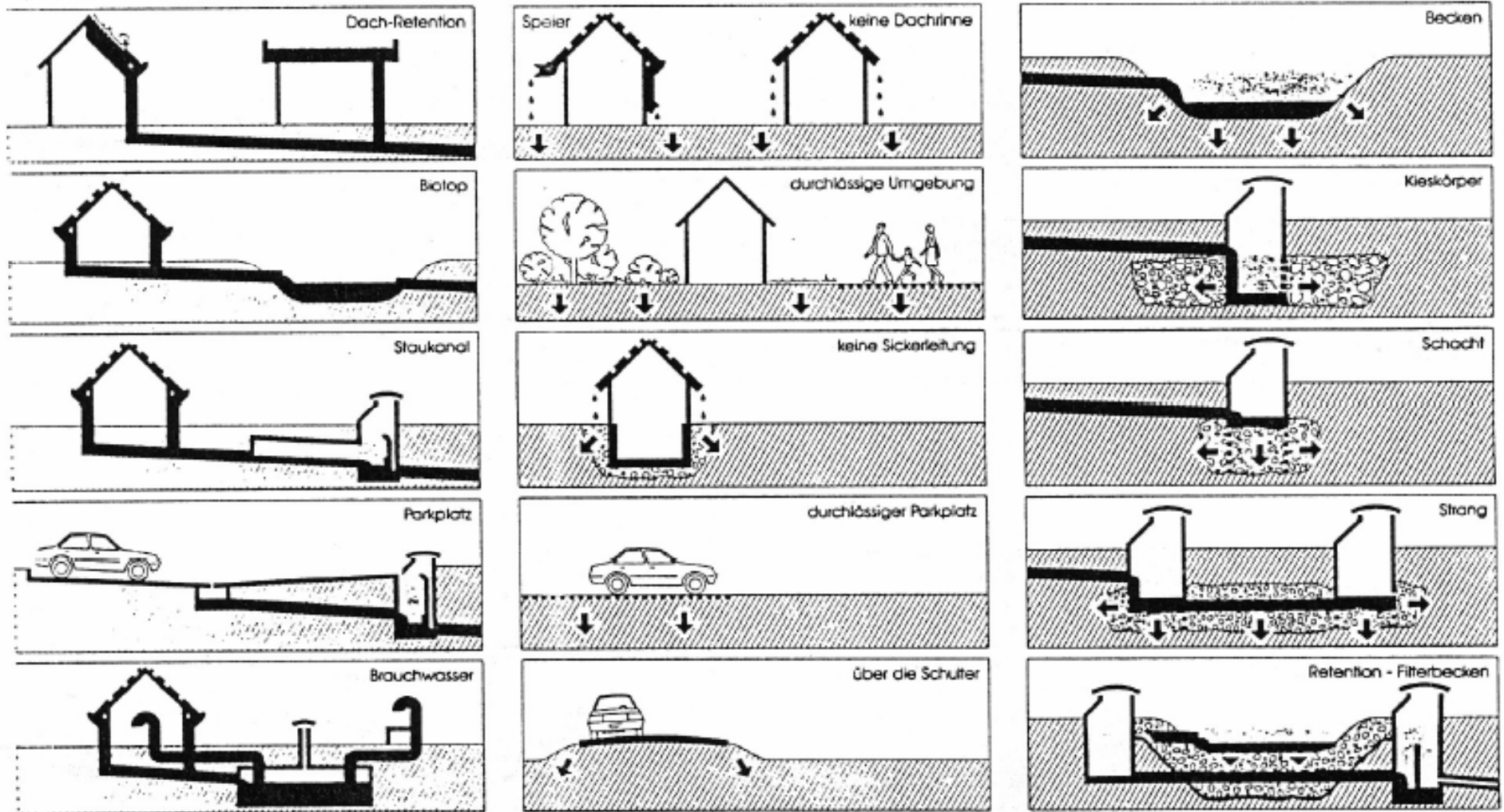

Construction of Sewers

Laying of sewer systems in

urban areas: on public properties; mainly streets.

- Supply systems below the sidewalks, sewer below the road.
- in co-ordination with other piped supply (gas, water supply, heat, but also electricity, telecommunication lines)

In rural areas: on private property is cost saving because there will be no expensive reconstruction of the pavement.

- Wastewater has to be laid deeper than drinking water pipes.
- Sewer systems should have a uniform gradient and be laid in a straight line (recovery)

Construction of Sewers

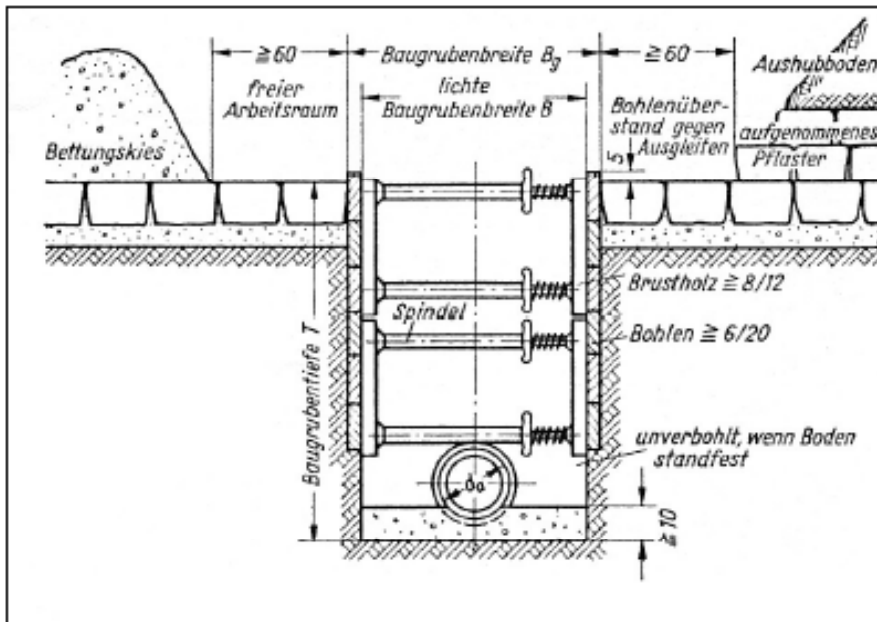

Open trench

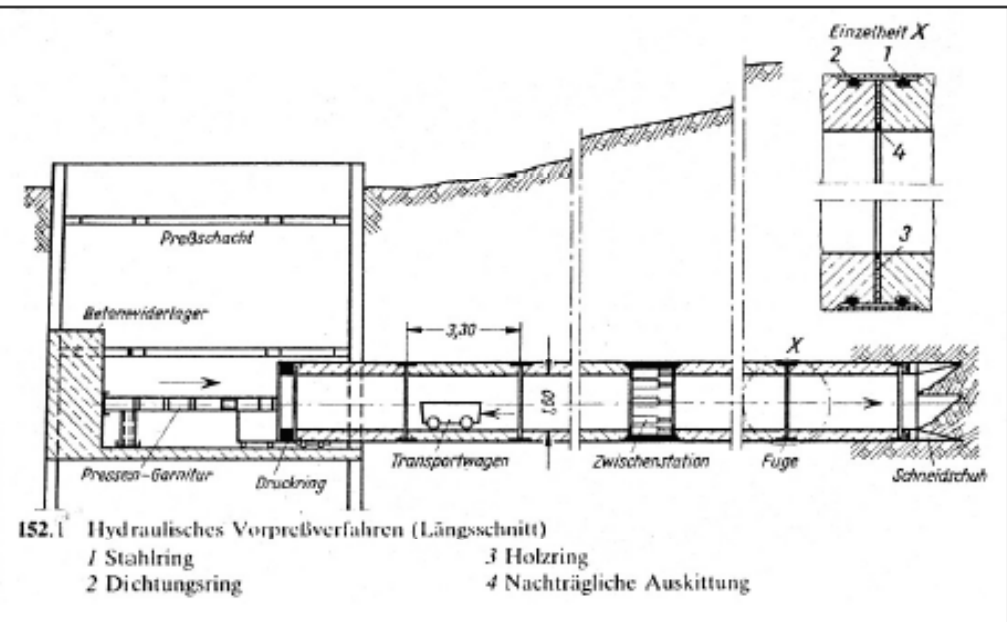

Tunnelling

Sewer shapes

Minimum pipe grade:

$I_{\min} = 0.3 \%$ for first sections of sewer
 $I_{\min} = 0.2 \%$ main sewer
 $I_{\min} = 0.1 \%$ transport sewer

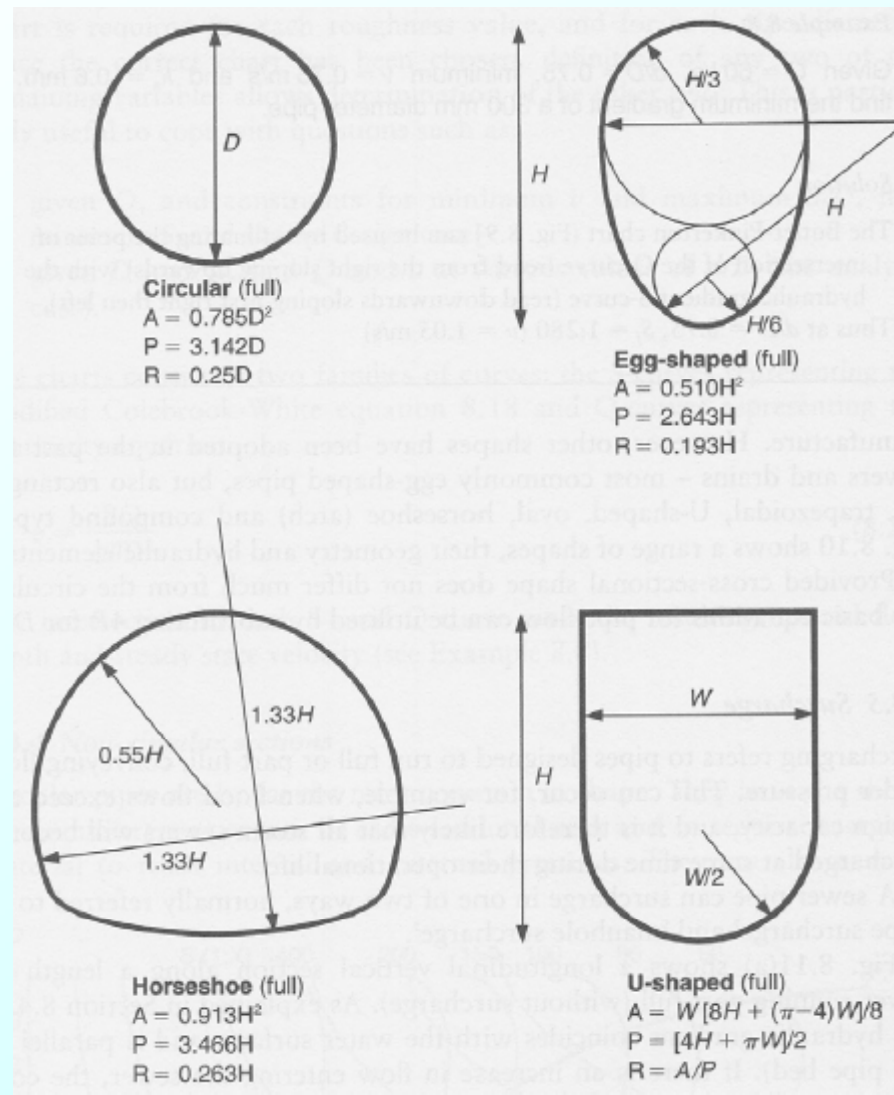

Sewer shapes

Circular shape:

Most common profile for small diameters (200 to 500 mm)

- Easy manufacturing and laying but
- Risk of sedimentations in combined systems (low flow velocity during dry-weather)

egg-shaped profiles:

In case of big differences between dry-weather and stormwater runoff

- Small diameter at the bottom of the pipe results in a higher flow velocity in case of dry weather.

Minimum diameter:

- DN (nominal pipe diameter) 250 for combined and storm sewer
 - DN 200 (DN 150) for sanitary sewer
-
- Large cross-sectional area of the profile to ensure the required capacity.



Special Structures – Manholes and Shafts

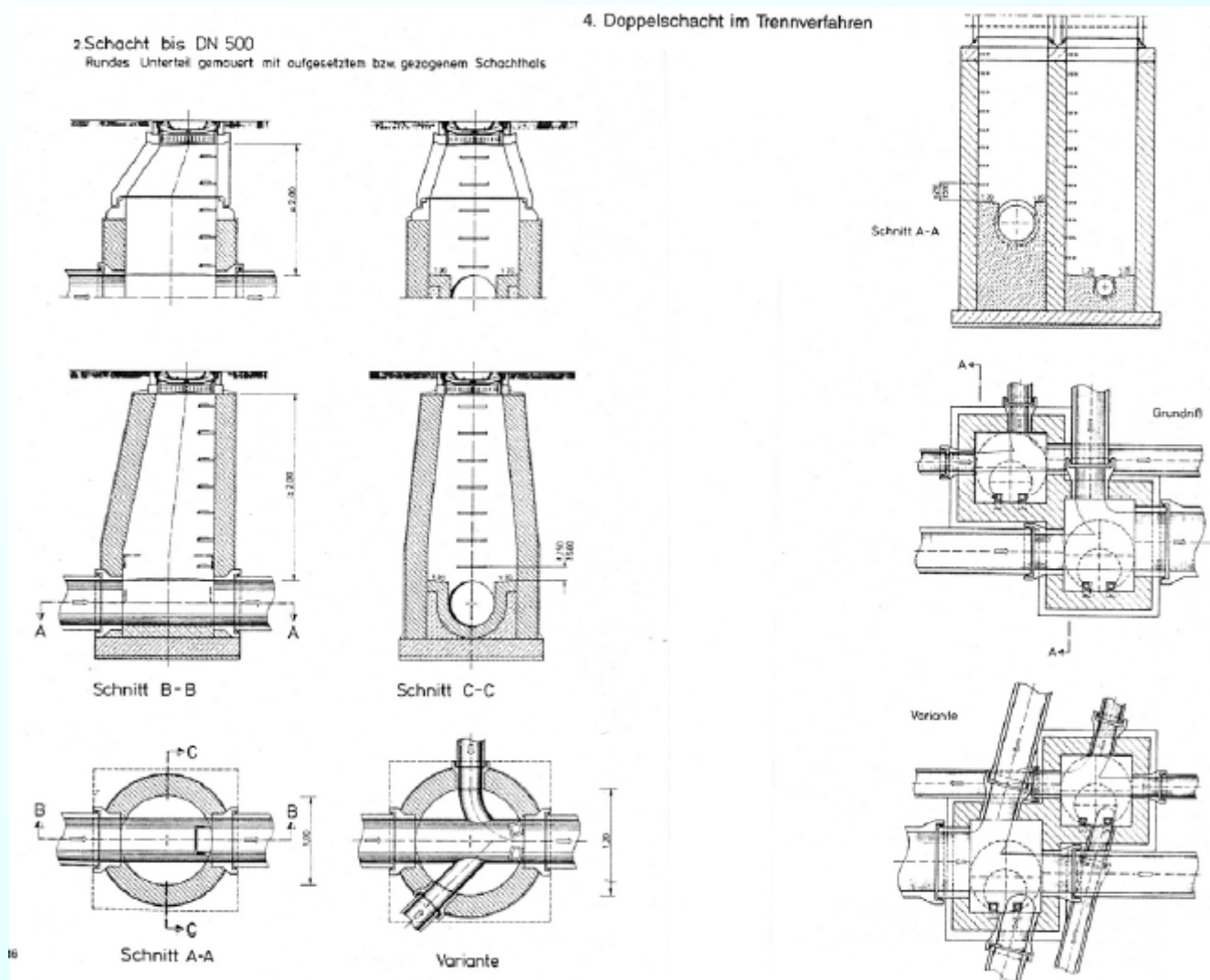

Special Structures – Junction structure, Drop structure

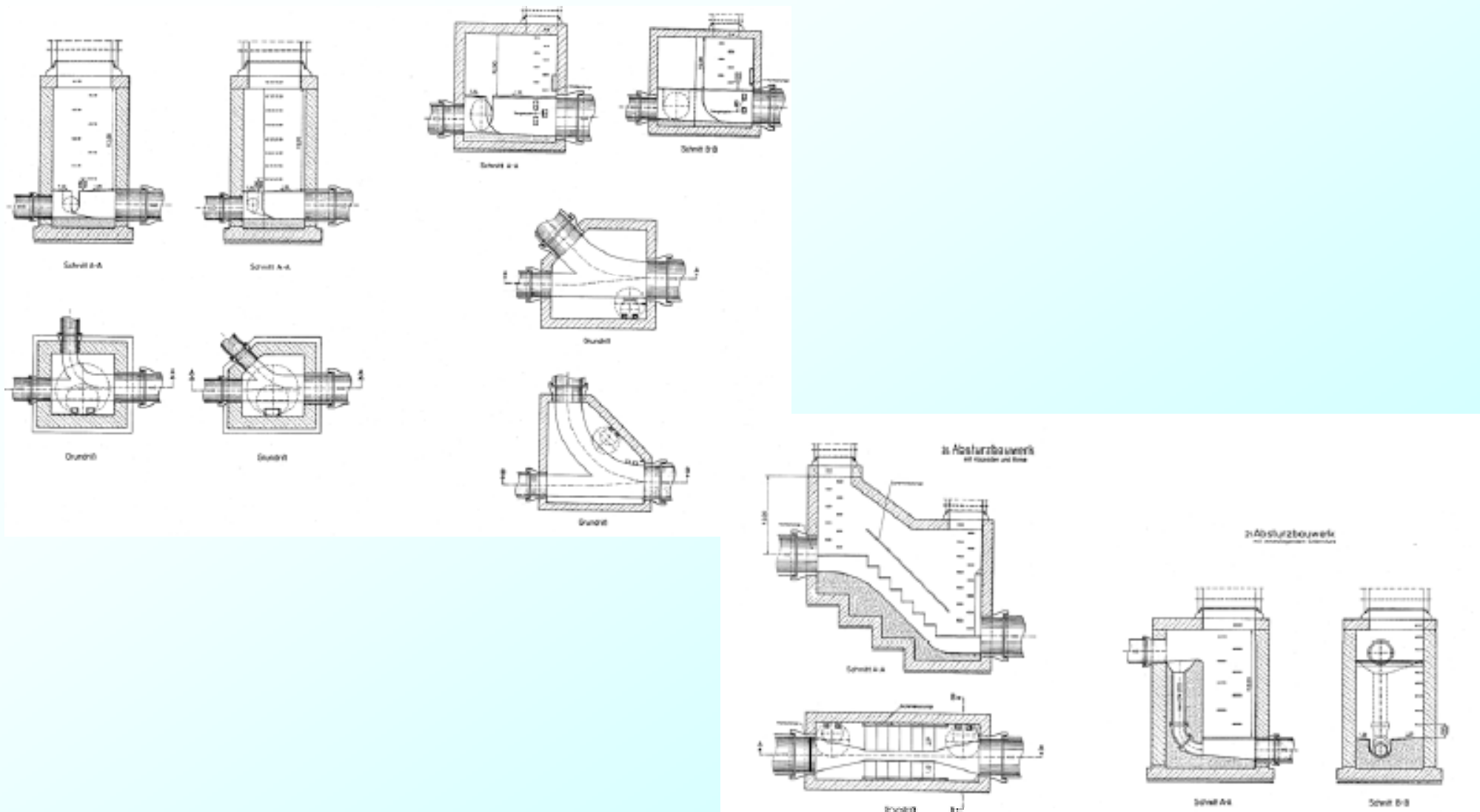

Combined Sewer: Overflow Structure & Retention Tank

In the line of the mainsewer



Bild 7: Durchlaufbecken im Hauptschluß

Beside the line of the mainsewer



Durchlaufbecken im Nebenschluß **Sedimentation**

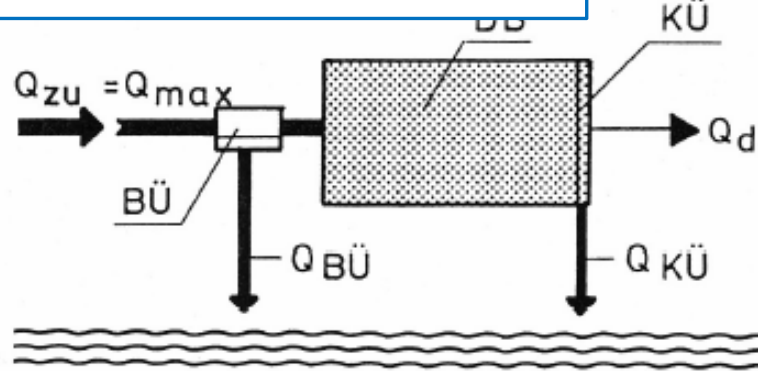
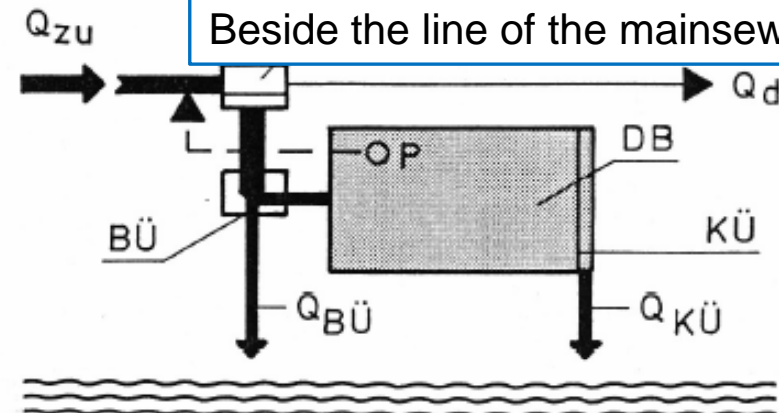
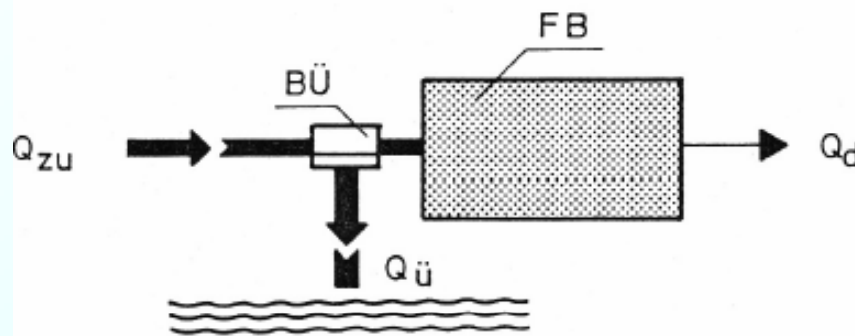

Fangbecken im Hauptschluß

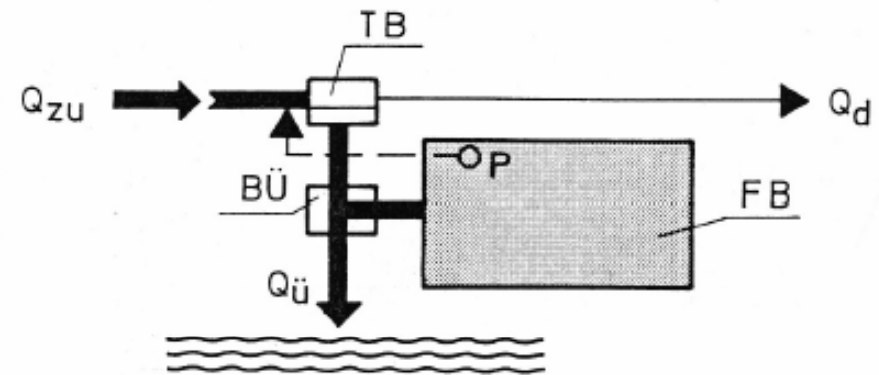

Fangbecken im Nebenschluß

retain first flush

Special Structures – Spiral pumping station

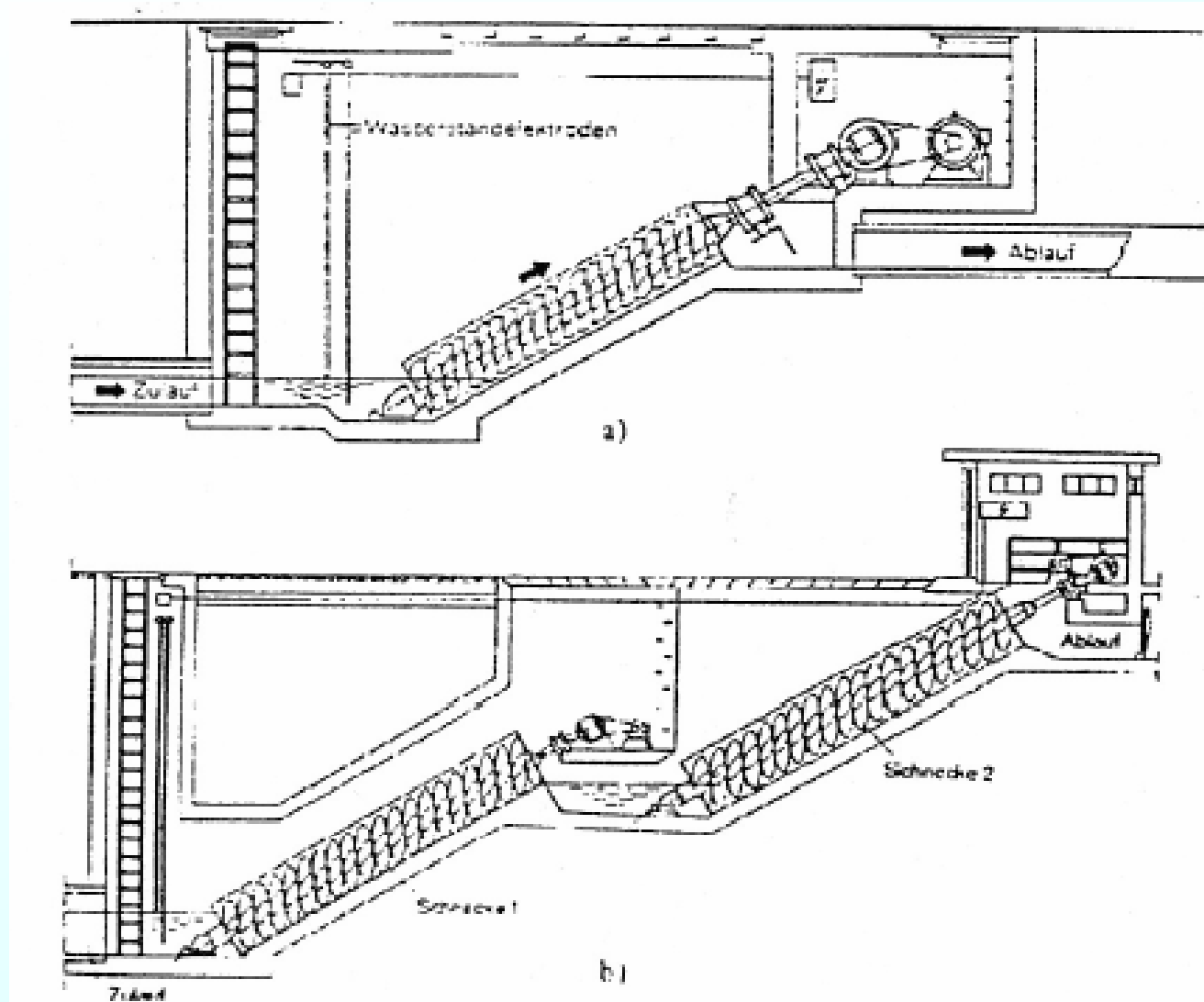

Special Structures – Spiral pumping station



Sewer Materials 28.11.2011

The most important characteristics are:

- Physical and chemical durability
- Impermeable
- Low deformation (static and dynamic load)
- pipe joints: easy to install and absolute watertight

Most common materials

- Clay (pottery) for small and medium-sized pipes
- Concrete (plain, reinforced or prestressed) for medium and large-sized pipes
- Fibre cement
- Synthetic materials:
 - **PVC-Polyvinylchloride, PE-Polyethylene, PP-Polypropylene**
 - **Glass Fibre Plastics**

Sewer Simulation - Modeling

1st step for all methods: **determine the surface runoff.**

- Easy way: use the peak discharge coefficient - method
- More accurate way: use runoff models

Modeling methods:

Hydrological methods

- simulate runoff on the basis of a **design rainfall intensity** via simplified transformations.

Hydrodynamical methods

- use St.Venant equations (continuity equation and equation of motion)

Design of Sewer Systems

- 1) Definition of the contributing Area (topographical catchment area, population)
 - Detail contours, physical features, road layout, buildings, sewers etc.
- 2) Draft of a preliminary horizontal alignment (preliminary system layout)
 - requirement to drain the whole contributing area and minimize pipe lengths.
- 3) Sizing the preliminary system
 - minimize excavation
 - Gradients not less than 1:5000 (0.02 %)
- 4) Preliminary vertical alignment (vertical layout)
 - All users can connect to the system; avoid pumping if anyhow possible.
- 5) Revise the layout – horizontal and vertical alignment
 - minimize system cost by reducing pipe lengths, sizes, and depths.

